

I Lucci Argentati, school of *light*.

design Dodo Arslan
terzani.com

TERZANI
LA LUCE PENSATA



Product Name
I Lucci Argentati
small linear chandelier

Materials
metal



Finishes | Code

-  white
ON82S M2 C8. L
-  brushed nickel
ON82S H4 C8. L
-  brushed gold
ON82S L9 C8. L

Body

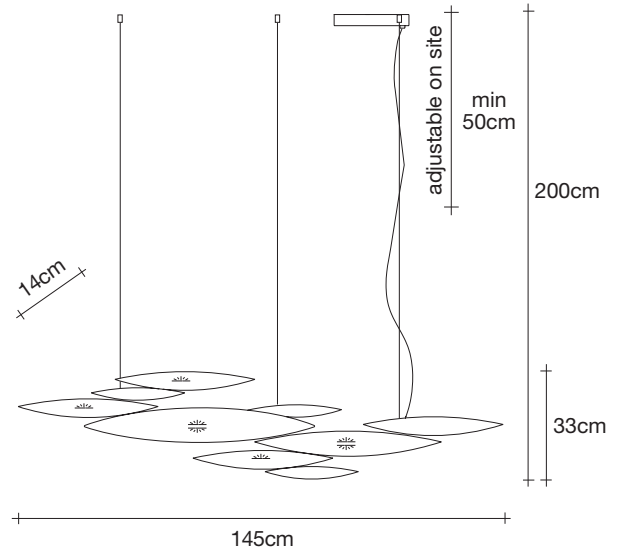

Integrated Led

100-240V ~ 50/60Hz

 LED integrated
7 x 4,5W 3710 lm CRI 90
3000K or optional 2700K

dimmable with

-  0/1-10V
PWM
10K-100K Ω
PUSH
DALI system

Canopy

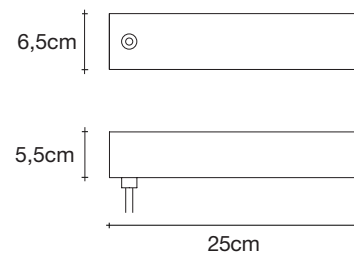

Canopy for DALI

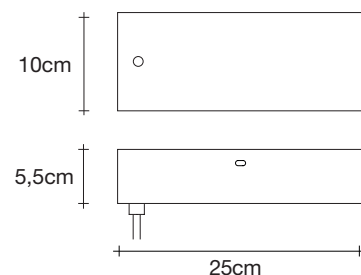

I Lucci Argentati draws from nature to create a whimsical, yet modern light. Recalling a school of fish darting through freshwater, it creates a mesmerizing luminescence. Sets of sleek lights combine to form a stunning pendant with thin incisions along the bottom creating an understated, tranquil beauty. Thanks to its modular system, I Lucci Argentati is customizable and can be combined in many different configurations: from small to extra large; as a pendant or sconce; and finished either in brushed nickel or white. Design Dodo Arslan.

I Lucci Argentati, school of *light*.

design Dodo Arslan
terzani.com



Product Name
I Lucci Argentati
medium linear chandelier

Materials
metal



Finishes | Code

-  white
ON83S M2 C8. L
-  brushed nickel
ON83S H4 C8. L
-  brushed gold
ON83S L9 C8. L

Body

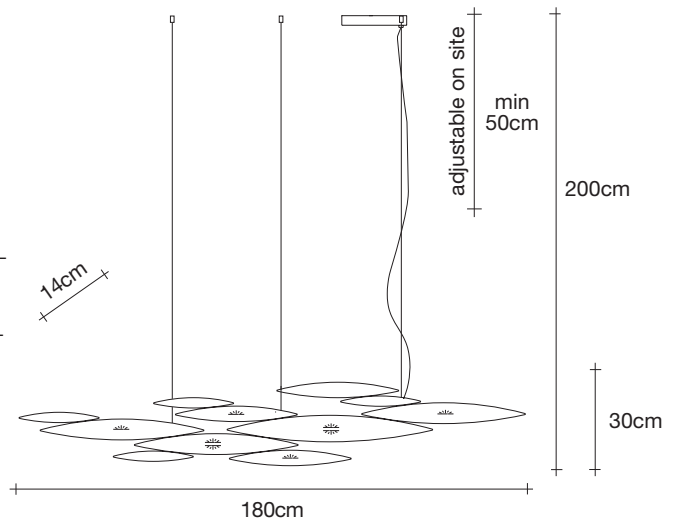

Integrated Led
100-240V ~ 50/60Hz

 LED integrated
8 x 4,5W 4240 lm CRI 90
3000K or optional 2700K

dimmable with

-  1-10V
PWM
10K-100K Ω
PUSH
DALI system

Canopy

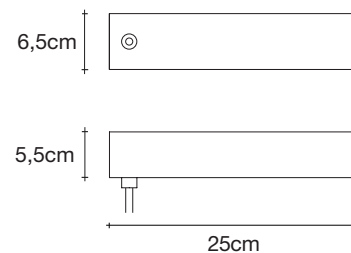

Canopy for DALI

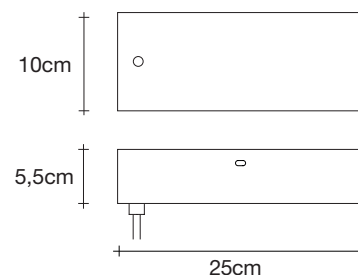

I Lucci Argentati draws from nature to create a whimsical, yet modern light. Recalling a school of fish darting through freshwater, it creates a mesmerizing luminescence. Sets of sleek lights combine to form a stunning pendant with thin incisions along the bottom creating an understated, tranquil beauty. Thanks to its modular system, I Lucci Argentati is customizable and can be combined in many different configurations: from small to extra large; as a pendant or sconce; and finished either in brushed nickel or white. Design Dodo Arslan.

I Lucci Argentati, school of *light*.

design Dodo Arslan
terzani.com



Product Name
I Lucci Argentati
large linear chandelier

Materials
metal



Finishes | Code

-  white
ON81S M2 C8. L
-  brushed nickel
ON81S H4 C8. L
-  brushed gold
ON81S L9 C8. L

Body

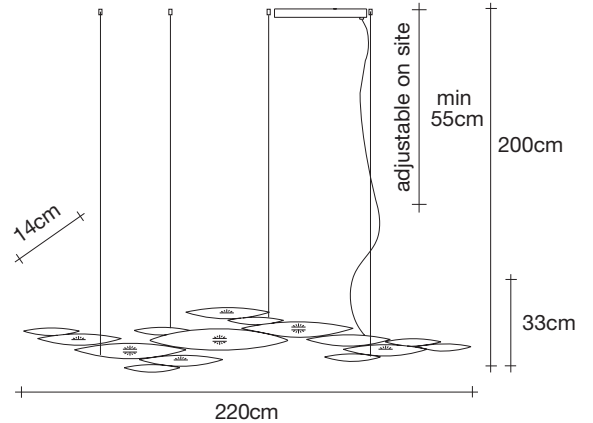

Integrated Led

230-240V ~ 50/60Hz

 LED integrated
10 x 4,5W 5300 lm CRI 90
3000K or optional 2700K

dimnable with

 0-10V
PUSH
DALI system

Canopy

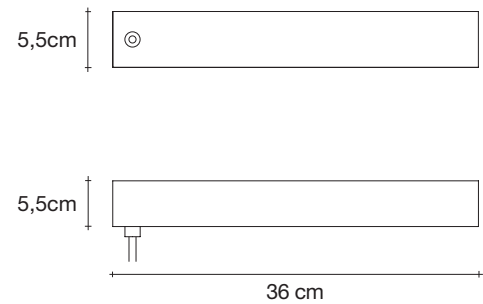

Canopy for DALI

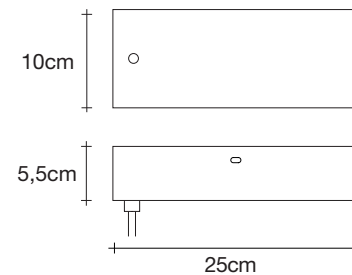

I Lucci Argentati draws from nature to create a whimsical, yet modern light. Recalling a school of fish darting through freshwater, it creates a mesmerizing luminescence. Sets of sleek lights combine to form a stunning pendant with thin incisions along the bottom creating an understated, tranquil beauty. Thanks to its modular system, I Lucci Argentati is customizable and can be combined in many different configurations: from small to extra large; as a pendant or sconce; and finished either in brushed nickel or white. Design Dodo Arslan.

I Lucci Argentati, school of *light*.

design Dodo Arslan
terzani.com



Product Name
I Lucci Argentati
xlarge linear chandelier

Materials
metal



Finishes | Code

-  white
ON80S M2 C8. L
-  brushed nickel
ON80S H4 C8. L
-  brushed gold
ON80S L9 C8. L

Body

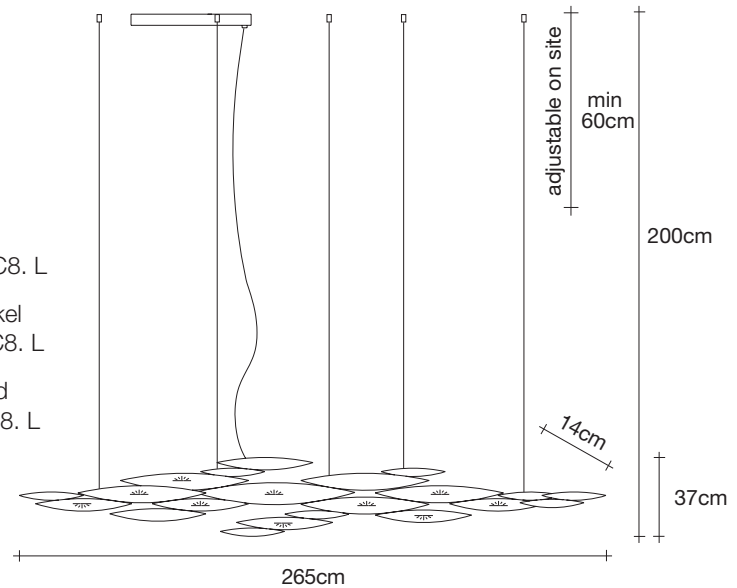

Integrated Led
230-240V ~ 50/60Hz

 LED integrated
10 x 4,5W 5300 lm CRI 90
3000K or optional 2700K

dimmable with

 0-10V
PUSH
DALI system

Canopy

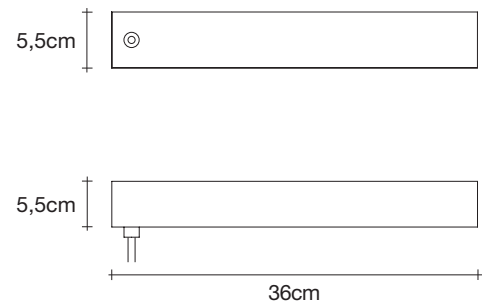

Canopy for DALI

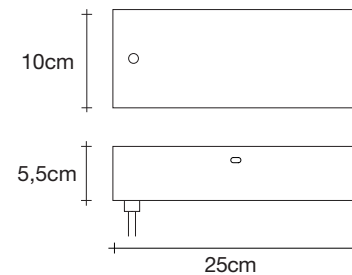

I Lucci Argentati draws from nature to create a whimsical, yet modern light. Recalling a school of fish darting through freshwater, it creates a mesmerizing luminescence. Sets of sleek lights combine to form a stunning pendant with thin incisions along the bottom creating an understated, tranquil beauty. Thanks to its modular system, I Lucci Argentati is customizable and can be combined in many different configurations: from small to extra large; as a pendant or sconce; and finished either in brushed nickel or white. Design Dodo Arslan.

I Lucci Argentati, school of *light*.

design Dodo Arslan
terzani.com



Product Name

I Lucci Argentati
wall sconce

Materials

metal



Finishes | Code

-  white
ON85A M2 C8. LB
-  brushed nickel
ON85A H4 C8. LB
-  brushed gold
ON85S L9 C8. L

Body

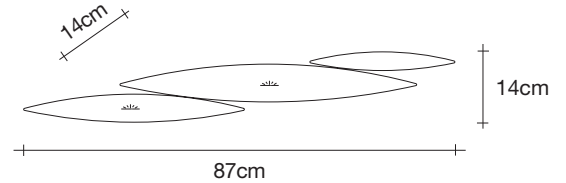

Integrated Led

100-240V ~ 50/60Hz

 LED integrated
2 x 4,5W 1060 lm CRI 90
3000K or optional 2700K

 dimmable with

 0/1-10V
PUSH
DALI system

Canopy

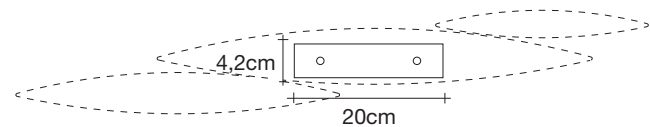

Canopy for DALI

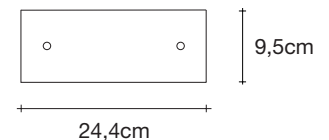

I Lucci Argentati draws from nature to create a whimsical, yet modern light. Recalling a school of fish darting through freshwater, it creates a mesmerizing luminescence. Sets of sleek lights combine to form a stunning pendant with thin incisions along the bottom creating an understated, tranquil beauty. Thanks to its modular system, I Lucci Argentati is customizable and can be combined in many different configurations: from small to extra large; as a pendant or sconce; and finished either in brushed nickel or white. Design Dodo Arslan.