

JAMES DESK / CLIP

DESIGN SPECIFICATIONS

DIMENSIONS (mm)	H 650 x D 510 - SHADE Ø 180
WEIGHT (kg)	1,5
MATERIALS	THE LAMP IS MADE FROM CLEAR LACQURED BRASS OR POWDER COATED STEEL.
CORD (mm)	BLACK TEXTILE - L 2025
ENVIRONMENT	INDOOR
DESIGN BY	NICLAS HOFLIN
DESIGN YEAR	2014

ELECTRICAL SPECIFICATIONS

SWITCH	ON / OFF
BULB HOLDER	NO
LIGHT SOURCE	INTERGRATED 10 W LED PANEL - 3000 K
DIMMABLE	YES
MAX (W)	10 W LED
VOLTAGE	230 / 240
CLASS	2
IP	20

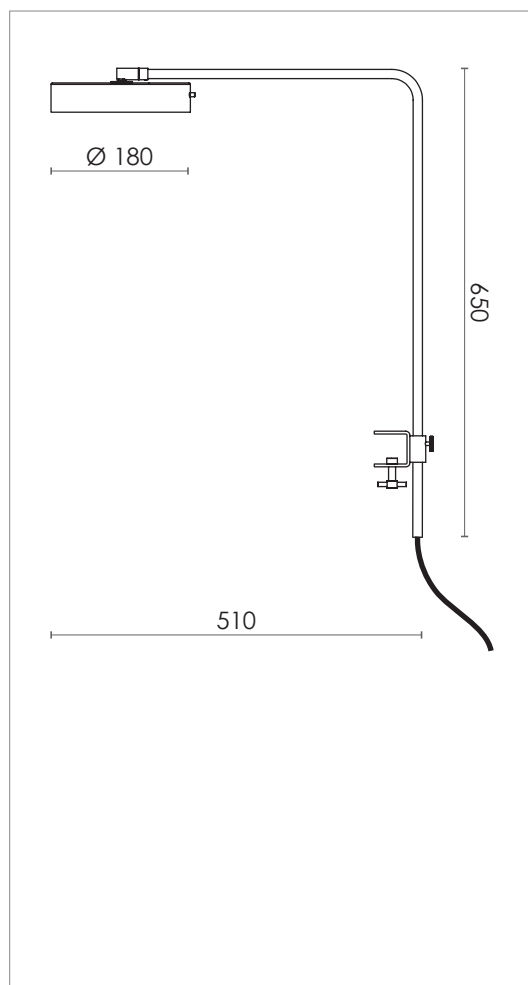

COLOURS



BLACK

ART.NO. 355140005



BRASS

ART.NO. 355140001